

## VC-A51P\_VC-A51PN RS-232 command set

No	Issue Date	Description	Apply Firmware
1	2021/10/05	First version.	VCAO100
2	2022/3/2	Add VC-A51PN	NA

**\*Notice:**

1. The RS-232 command list is for VC-A51P and VC-A51PN.
2. The yellow highlight  means the latest update.
3. The blue highlight  means the deleted item.

## 1. Communication Protocol

Transmit Method: Asynchronous Interface Half Duplex Serial Communication

- Transmit Speed: 9600bps or 38400bps
- Start bit: 1Bit
- Parity Check: NA
- Data Bit: 8Bit
- Stop Bit: 1Bit

## 2. The wire diagram

The RS232 wire diagram between presenter and remote controller as below

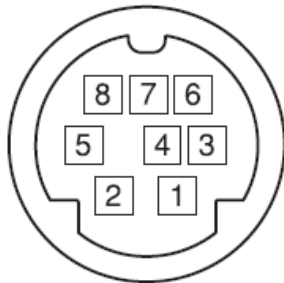

No	Pins
1	DTR IN
2	DSR IN
3	TXD IN
4	GND
5	RXD IN
6	GND

## 1. ACK & Completion message

	Reply Packet	Note
<b>Ack</b>	X0 4Y FF	Y = socket number
<b>Completion (commands)</b>	X0 5Y FF	Y = socket number
<b>Completion (Inquiries)</b>	X0 5Y ... FF	Y = socket number
X = 9 to F==>camera address + 8 , Y=1 to 2		

2. Error message

Error Packet	Description
X0 60 02 FF	Syntax Error
X0 60 03 FF	Command buffer full
X0 6Y 04 FF	Command cancelled
X0 6Y 05 FF	No socket (to be cancelled)
X0 6Y 41 FF	Command not executable
X = 9 to F==>camera address + 8, Y = socket number, Y=0 to 2, 0: Inquiry not execution	

3. Command execution cancel

	Cancel Packet	Note
Cancel	8X 2Y FF	Y = socket number
X = 1 to 7==>camera address, Y = socket number, Y=1 to 2		

4. Network Change

	Packet	Note
Address	88 30 01 FF	Always broadcasted
Network Change	X0 38 FF	
X = 9 to F==>camera address + 8		

5. IF\_Clear

	Command	Reply Packet Note
IF_Clear	8X 01 00 01 FF	X0 50 FF
IF_Clear (broadcast)	88 01 00 01 FF	88 01 00 01 FF
X = 1 to 7==>camera address (For inquiry packet)		
X = 9 to F==>camera address +8 (For reply packet)		

**6. Zoom Focus Position Table**

Zoom Position	Wide end		Tele end
	0000	to	4000
Focus Position	Far end		Near end
	000	to	575

**7. AE\_Iris Table**

	Index(pq)	Value
<b>Iris</b>	0F	-
	0E	F 1.6
	0D	F 2.0
	0C	F 2.2
	0B	F 2.7
	0A	F 3.2
	09	F 3.8
	08	F 4.5
	07	F 5.4
	06	F 6.3
	05	-
	04	-
	03	-
	02	-
	01	-
	00	-

8. AE\_Shutter Table

	Index(pq)	60/30 mode	50/25 mode
Shutter Speed	00	1/10000	1/10000
	01	1/5000	1/5000
	02	1/3000	1/3000
	03	1/2500	1/2500
	04	1/2000	1/1750
	05	1/1500	1/1250
	06	1/1000	1/1000
	07	1/725	1/600
	08	1/500	1/425
	09	1/350	1/300
	0A	1/250	1/215
	0B	1/180	1/150
	0C	1/120	1/120
	0D	1/100	1/100
	0E	1/90	1/75
	0F	1/60	1/50
10	1/30	1/25	
11	1/15	1/12	
12	1/8	1/6	
13	1/4	1/3	
14	1/2	1/2	
15	1/1	1/1	

9. **AE\_Iris Limit Table**

	<b>Index(pq)</b>	<b>Value</b>
Iris	0x07	F 1.6
	0x06	F 2.2
	0x05	F 3.2
	0x04	F 4.5
	0x03	F 6.3

10. **AE\_Gain Table**

	<b>Index(pq)</b>	<b>Value</b>
Gain	0F	+45 dB
	0E	+42 dB
	0D	+39 dB
	0C	+36 dB
	0B	+33 dB
	0A	+30 dB
	09	+27 dB
	08	+24 dB
	07	+21 dB
	06	+18 dB
	05	+15 dB
	04	+12 dB
	03	+9 dB
	02	+6 dB
	01	+3 dB
	00	0 dB

## 11. Camera Command List

Command Set	Command	Command Packet	Comments
AddressSet	Broadcast	88 30 01 FF	Address setting
IF_Clear	Broadcast	88 01 00 01 FF	I/F Clear
CommandCancel	–	8x 2p FF	p: Socket No. (=1 or 2)
CAM_Power	On	8x 01 04 00 02 FF	Power ON/OFF
	Off (Standby)	8x 01 04 00 03 FF	
CAM_AutoPowerOff	Direct	8x 01 04 40 0p 0q 0r 0s FF	<p>Auto Power Off, pqrs: 0000 To FFFF</p> <p>pqrs: Power Off Timer 0000 (Timer Off) to FFFF (65535min)</p> <p>Initial value: 0000</p> <p>The power automatically turns off if the camera does not receive any VISCA commands or any signals from the Remote Commander for the duration you set in the timer.</p>
CAM_Zoom	Stop	8x 01 04 07 00 FF	
	Tele (Standard)	8x 01 04 07 02 FF	
	Wide (Standard)	8x 01 04 07 03 FF	
	Tele Step	8x 01 04 07 04 FF	
	Wide Step	8x 01 04 07 05 FF	
	Tele (Variable)	8x 01 04 07 2p FF	p=0 (Low) to 7 (High)
	Wide (Variable)	8x 01 04 07 3p FF	
	Direct	8x 01 04 47 0p 0q 0r 0s FF	pqrs: Zoom Position(0x0000~0x4000) , Optical Zoom Tele max position: 0x4000
	Direct(Speed Variable)	8x 01 04 47 0p 0q 0r 0s 0t FF	pqrs: Zoom Position(0x0000~0x4000) , Optical Zoom Tele max position: 0x4000, t:0~7(0 :Low, 7:High)

Command Set	Command	Command Packet	Comments
VISCA_OPTICAL_ZOOM_LIMIT	-	8x 01 04 47 0p 0q FF	pq: 0 ~ 0x13(Ratio : x1 ~ x20)
CAM_Focus	Stop	8x 01 04 08 00 FF	p=0 (Low) to 7 (High) (* Enabled during Manual Focus Mode)
	Far (Standard)	8x 01 04 08 02 FF	
	Near (Standard)	8x 01 04 08 03 FF	
	Far Step	8x 01 04 08 04 FF	
	Near Step	8x 01 04 08 05 FF	
	Far (Variable)	8x 01 04 08 2p FF	
	Near (Variable)	8x 01 04 08 3p FF	
	Direct	8x 01 04 48 0p 0q 0r 0s FF	pqrs: Focus Position , pqrs parameters are in the General Zoom Foucs Table 0x00 ~ 0x3C3 (* Enabled during Manual Focus Mode)
	Auto Focus	8x 01 04 38 02 FF	AF ON/OFF
	Manual Focus	8x 01 04 38 03 FF	
	Auto/Manual	8x 01 04 38 10 FF	
One Push Trigger	8x 01 04 18 01 FF	One Push AF Trigger(* Enabled during Manual Focus Mode)	
VISCA_MF_ZOOM_TRACKING	Zoom Tracking Switch	8x 01 04 38 03 0p FF	p: 0(OFF) 、 1(ON)
AF Sensitivity	High	8x 01 04 58 01 FF	High / Middle / Low
	Middle	8x 01 04 58 02 FF	
	Low	8x 01 04 58 03 FF	
CAM_ZoomFocus	Direct	8x 01 04 47 0p 0q 0r 0s 0t 0u 0v 0w FF	pqrs: Zoom Position(0x0000~0x4000) tuv: Focus Position(0x00 ~ 0x575) (* Enabled during Manual Focus Mode)



Command Set	Command	Command Packet	Comments
Resolution Settting	Select Resolution	8x 01 06 35 00 0p FF	p: 0x00:1080p-60 0x01:1080p-59.94 0x02:1080p-50 0x03:1080p-30 0x04:1080p-29.97 0x05:1080p-25 0x06:1080i-60 0x07:1080i-59.94 0x08:1080i-50 0x09:720p-60 0x0A:720p-59.94 0x0B:720p-50
CAM_WB	Auto	8x 01 04 35 00 FF	Normal Auto
	Indoor	8x 01 04 35 01 FF	Indoor mode
	Outdoor	8x 01 04 35 02 FF	Outdoor mode
	One Push WB	8x 01 04 35 03 FF	One Push WB mode
	ATW	8x 01 04 35 04 FF	Auto Tracing White Balance
	Manual	8x 01 04 35 05 FF	Manual mode
	Sodium Lamp	8x 01 04 35 06 FF	Sodium lamp source fixed mode
	3000K	8x 01 04 35 07 FF	Color temperture fixed at 3000K mode
	4300K	8x 01 04 35 08 FF	Color temperture fixed at 4300K mode
	5000K	8x 01 04 35 09 FF	Color temperture fixed at 5000K mode
	6500K	8x 01 04 35 0A FF	Color temperture fixed at 6500K mode
	8000K	8x 01 04 35 0B FF	Color temperture fixed at 8000K mode
WideAuto	8x 01 04 35 0C FF	Wide Auto mode	

Command Set	Command	Command Packet	Comments
	One Push Trigger	8x 01 04 10 05 FF	One Push WB Trigger(* Enabled during One Push WB Mode)
CAM_WB_RGAIN	Reset	8x 01 04 03 00 FF	Manual R gain Setting
	Up	8x 01 04 03 02 FF	(* Enabled during WB Manual mode )
	Down	8x 01 04 03 03 FF	pq = 0x00 To 0x80
	Direct	8x 01 04 43 00 00 0p 0q FF	
CAM_WB_BGAIN	Reset	8x 01 04 04 00 FF	Manual B gain Setting
	Up	8x 01 04 04 02 FF	(* Enabled during WB Manual mode )
	Down	8x 01 04 04 03 FF	pq = 0x00 To 0x80
	Direct	8x 01 04 44 00 00 0p 0q FF	
CAM_AE	Full Auto	8x 01 04 39 00 FF	Automatic Exposure mode
	Manual	8x 01 04 39 03 FF	Manual Control mode
	Shutter Priority	8x 01 04 39 0A FF	Shutter Priority Automatic Exposure mode
	Iris Priority	8x 01 04 39 0B FF	Iris Priority Automatic Exposure mode
CAM_Shutter	Reset	8x 01 04 0A 00 FF	"Shutter Setting
	Up	8x 01 04 0A 02 FF	(* Enabled during AE Shutter Priority/Manual Mode)"
	Down	8x 01 04 0A 03 FF	
	Direct	8x 01 04 4A 00 00 0p 0q FF	
CAM_Iris	Reset	8x 01 04 0B 00 FF	Iris Setting
	Up	8x 01 04 0B 02 FF	(* Enabled during Iris Priority/Manual Mode)
	Down	8x 01 04 0B 03 FF	
	Direct	8x 01 04 4B 00 00 0p 0q FF	pq: Iris Position , pq: 00 To 0E
	Iris Limit	8x 01 04 2B 0p FF	p: Iris F number , p: 3 To 7 (* Disabled during AE Manual Mode and IrisPri Mode)
CAM_Gain	Reset	8x 01 04 0C 00 FF	Gain Setting

Command Set	Command	Command Packet	Comments
	Up	8x 01 04 0C 02 FF	(* Enabled during AE Manual Mode)
	Down	8x 01 04 0C 03 FF	
	Direct	8x 01 04 4C 00 00 0p 0q FF	pq: Gain Position, pq:00 To 0F (* Enabled during AE Manual Mode) (* 0dB ~ +45dB)
	Gain Limit	8x 01 04 2C 0p FF	p: Gain Position , p: 3 To F (* Disabled during AE Manual Mode)
CAM_ExpComp	On	8x 01 04 3E 02 FF	Exposure Compensation ON/OFF
	Off	8x 01 04 3E 03 FF	
	Reset	8x 01 04 0E 00 FF	Exposure Compensation Amount Setting (* Enabled during ExpComp On )
	Up	8x 01 04 0E 02 FF	
	Down	8x 01 04 0E 03 FF	
	Direct	8x 01 04 4E 00 00 0p 0q FF	pq: ExpComp Position , pq: 00 To 0A (* Enabled during ExpComp On )
	Direct	8x 01 04 4E 00 00 0p 0q FF	pq: ExpComp Position , pq: 00 To 0B (* Enabled during ExpComp On )
CAM_BackLight	On	8x 01 04 33 02 FF	Back Light Compensation ON/OFF
	Off	8x 01 04 33 03 FF	
CAM_WDR	Set Parameter	8x 01 04 2D 0p FF	WDR Mode p:0~5
CAM_Aperture (Sharpness)	Reset	8x 01 04 02 00 FF	Aperture Control
	Up	8x 01 04 02 02 FF	

Command Set	Command	Command Packet	Comments
	Down	8x 01 04 02 03 FF	
	Direct	8x 01 04 42 00 00 0p 0q FF	pq: Aperture Gain, pq: 00 To 0F
CAM_HR	On	8x 01 04 52 02 FF	High-Resolution Mode ON/OFF
	Off	8x 01 04 52 03 FF	
CAM_2DNR	Set 2DNR Level	8x 01 04 53 0p FF	p: NR Setting , p: 0 To 6 (0: Auto,1:Off 6: Max )
CAM_3DNR	Set 3DNR Level	8x 01 04 54 0p FF	p: NR Setting , p: 0:Off 1:Low 2:Typ 3:Max 4:Auto
CAM_Gamma	Gamma setting	8x 01 04 5B 0p FF	p: 0 To 3 (* Enabled during Image Mode = Custom mode )
CAM_HighSensitivity	On	8x 01 04 5E 02 FF	High Sensitivity mode ON/OFF
	Off	8x 01 04 5E 03 FF	
CAM_LR_Reverse	On	8x 01 04 61 02 FF	Mirror Image ON/OFF
	Off	8x 01 04 61 03 FF	
CAM_Freeze	On	8x 01 04 62 02 FF	Still Image ON/OFF
	Off	8x 01 04 62 03 FF	
CAM_PictureEffect	Off	8x 01 04 63 00 FF	Picture Effect Setting
	Neg.Art	8x 01 04 63 02 FF	
	B&W	8x 01 04 63 04 FF	
CAM_PictureFlip	On	8x 01 04 66 02 FF	Picture flip ON/OFF
	Off	8x 01 04 66 03 FF	
CAM_Memory	Reset	8x 01 04 3F 00 pp FF	pp: Memory Number (pp: 0x00 To 0x7F)

Command Set	Command	Command Packet	Comments
(Preset)	Set	8x 01 04 3F 01 pp FF	(* Preset address : 0~127) (* Preset address : 0 mapping preset 1 on webpage and remote)
	Recall	8x 01 04 3F 02 pp FF	
CAM_Mute	On	8x 01 04 75 02 FF	Mute ON
	Off	8x 01 04 75 03 FF	Mute OFF
	On/Off	8x 01 04 75 10 FF	Mute Trigger
CAM_ColorGain(Saturation)	Direct	8x 01 04 49 00 00 00 pq FF	pq:0x00~0x19 (* Enabled during Image Mode = Custom mode )
IR_Receive	On	8x 01 06 08 02 FF	IR(remote commander) receive ON/OFF
	Off	8x 01 06 08 03 FF	
	On/Off	8x 01 06 08 10 FF	
IR_ReceiveReturn	On	8x 01 7D 01 03 00 00 FF	IR (remote commander) receive message via the VISCA communication ON/OFF
	Off	8x 01 7D 01 13 00 00 FF	
Pan-tiltDrive	Up	8x 01 06 01 VV WW 03 01	VV: Pan speed 0x01 (low speed) to 0x18 (high speed) WW: Tilt Speed 0x01 (low speed) to 0x18 (high speed)
	Down	8x 01 06 01 VV WW 03 02 FF	VV: Pan speed 0x01 (low speed) to 0x18 (high speed) WW: Tilt Speed 0x01 (low speed) to 0x18 (high speed)
	Left	8x 01 06 01 VV WW 01 03 FF	VV: Pan speed 0x01 (low speed) to 0x18 (high speed) WW: Tilt Speed 0x01 (low speed) to 0x18 (high speed)
	Right	8x 01 06 01 VV WW 02 03 FF	VV: Pan speed 0x01 (low speed) to 0x18 (high speed) WW: Tilt Speed 0x01 (low speed) to 0x18 (high speed)
	UpLeft	8x 01 06 01 VV WW 01 01 FF	VV: Pan speed 0x01 (low speed) to 0x18 (high speed) WW: Tilt Speed 0x01 (low speed) to 0x18 (high speed)

Command Set	Command	Command Packet	Comments
	UpRight	8x 01 06 01 VV WW 02 01 FF	VV: Pan speed 0x01 (low speed) to 0x18 (high speed) WW: Tilt Speed 0x01 (low speed) to 0x18 (high speed)
	DownLeft	8x 01 06 01 VV WW 01 02 FF	VV: Pan speed 0x01 (low speed) to 0x18 (high speed) WW: Tilt Speed 0x01 (low speed) to 0x18 (high speed)
	DownRight	8x 01 06 01 VV WW 02 02 FF	VV: Pan speed 0x01 (low speed) to 0x18 (high speed) WW: Tilt Speed 0x01 (low speed) to 0x18 (high speed)
	Stop	8x 01 06 01 VV WW 03 03 FF	
	AbsolutePosition	8x 01 06 02 VV WW 0Y 0Y 0Y 0Y 0Z 0Z 0Z 0Z FF	YYYY : Pan Position 0x0000 to 0x6A40 & 0x95C0 to 0xFFFF (center 0000) ZZZZ : Tilt Position 0x0000 to 0x3840 & 0xED40 to 0xFFFF (center 0000)
	RelativePosition	8x 01 06 03 VV WW 0Y 0Y 0Y 0Y 0Z 0Z 0Z 0Z FF	YYYY : Pan Position 0x0000 to 0x6A40 & 0x95C0 to 0xFFFF (center 0000) ZZZZ : Tilt Position 0x0000 to 0x3840 & 0xED40 to 0xFFFF (center 0000)
	Home	8x 01 06 04 FF	
Reset	8x 01 06 05 FF		
Pan-tiltLimitSet	LimitSet	8x 01 06 07 00 0W 0Y 0Y 0Y 0Y 0Z 0Z 0Z 0Z FF	W: 1 UpRight YYYY: Pan Limit Position 0x0000~0x6A40 ZZZZ: Tilt Limit Position 0x0000~0x3840 W: 0 DownLeft YYYY: Pan Limit Position 0xFFFF~0x95C0 ZZZZ: Tilt Limit Position 0xFFFF~0xED40
	LimitClear	8x 01 06 07 01 0W 07 0F 0F 0F 07 0F 0F 0F FF	W: 1:Right,UP 清除, 0:Left, Down 清除
Firmware	Firmware version	8x 01 02 03 FF	
Error Code	Read Error Code	8x 01 01 01 FF	
	Clear Error Code Record	8x 02 02 02 FF	

Command Set	Command	Command Packet	Comments
Factory Reset	System Factory Reset	8x 01 04 3F 03 00 FF	
CAM_HARDWARE_FACTORY_RESET	System Hardware Factory Reset	8x 01 CD 0p FF	p: 1, 1: Enable
CAM_Image_Mode	Select CAM Image Mode	8x 01 04 3F 04 0p FF	p: 0~6, 6:Custom mode
CAM Prompt	Set Prompt On/Off	8x 01 04 07 00 0p FF	OSD Prompt ON/OFF
CAM Model ID	Set Camera model ID	8x 01 04 23 pp qq rr ss FF	ppqq: Vender ID , rrss:Model ID, default: SRG-300 (Vender ID = 0xEEEE)
AF Speed	Normal	8x 01 04 56 02 FF	Set anytime AF speed : Normal / Fast
	Fast	8x 01 04 56 03 FF	
CAM_ImageModeBrightness	Set Brightness	8x 01 04 75 67 pq FF	pq: 0x00~0x19(* Enabled during Image Mode = Custom mode )
CAM_ImageModeContrast	Set Contrast	8x 01 04 75 68 pq FF	pq: 0x00~0x19(* Enabled during Image Mode = Custom mode )
CAM_Skin_Tone	select red level	8x 01 04 75 06 0p FF	p: 0~5(* Enabled during Image Mode = Custom mode )
Black Level	Black Level	8x 01 04 75 69 0p FF	p: 0 to 5, 0:Off, 1:Type 1, 2:Type 2, 3:Type 3, 4:Type 4, 5:Type 5 (* Enabled during Image Mode = Custom mode )
SYS_Menu	On	8x 01 06 06 02 FF	turn on the menu screen
	Off	8x 01 06 06 03 FF	turn off the menu screen
	On/Off	8x 01 06 06 10 FF	turn on/off the menu screen
	Enter	8x 01 7E 01 02 00 01 FF	menu enter
	Up	8x 01 06 01 01 01 03 01 FF	menu up
	Down	8x 01 06 01 01 01 03 02 FF	menu down
	Left	8x 01 06 01 01 01 01 03 FF	menu left
	Right	8x 01 06 01 01 01 02 03 FF	menu right

RS158 - VC-A51P\_VC-A51PN RS-232 command set

Command Set	Command	Command Packet	Comments
Pan speed table update command	-	8x 01 06 1A 0p 0q 0r 0s 0u 0v FF	pqrs: 0x0 ~ 0xFFFF , uv: 0x1 ~ 0x64
Tilt speed table update command	-	8x 01 06 1B 0p 0q 0r 0s 0u 0v FF	pqrs: 0x0 ~ 0xFFFF , uv: 0x1 ~ 0x64
Pan/Tilt speed table to default	-	8x 01 06 1C 0p 0q 0D 0E 0F FF	pq: 0x18 or 0x64
Pan/tilt speed table size	-	8x 01 06 1D 0p 0q FF	pq: 0x18 or 0x64
Pan/tilt speed table save	-	8x 01 06 1E FF	
CAM_SET_ETHERNET_DHCP	Ethernet DHCP Enable/Disable	8x 01 CC 0p FF	p: 0~1 , 0: Disable 1: Enable
CAM_HARDWARE_FACTORY_RESET	System Hardware Factory Reset	8x 01 CD 0p FF	p: 1, 1: Enable
CAM_MSDC_RESET	MSDC Storage Reset	8x 01 CE 0p FF	p: 1, 1: Enable
Tally Mode	-	8x 01 7E 01 0A 01 0p FF	p: 0: (Power LED:Green Standby:OFF) 5: (Power LED:Red Standby:Red) - Tally Lamp must be Enabled 6: (Power LED: Green Standby:Red) - Tally Lamp must be Enabled 7: (Power LED: OFF Standby:OFF) - Tally Lamp must be Enabled
Tally_Lamp	On	8x 01 7E 01 0A 00 02 FF	Tally Lamp ON/OFF
	Off	8x 01 7E 01 0A 00 03 FF	
CAM_SET_IP_Address_IPv4	Set IP Address	8x 01 CC 01 0p 0q 0r 0s 0t 0u 0v 0w FF	address : pq.rs.tu.vw (HEX), pq = 0~255, rs = 0~255, tu = 0~255, vw = 0~255, e.g. 192.168.100.150 => 81 01 CC 01 0C 00 0A 08 06 04 09 06 FF



Command Set	Command	Command Packet	Comments
CAM_SET_IP_Netmask	Set Subnet Mask	8x 01 CC 02 0p 0q 0r 0s 0t 0u 0v 0w FF	address : pq.rs.tu.vw (HEX), pq = 0~255, rs = 0~255, tu = 0~255, vw = 0~255, e.g. 255.255.255.0 => 81 01 CC 02 0F 0F 0F 0F 0F 00 00 FF
CAM_SET_IP_Getway	Set Gateway	8x 01 CC 03 0p 0q 0r 0s 0t 0u 0v 0w FF	address : pq.rs.tu.vw (HEX), pq = 0~255, rs = 0~255, tu = 0~255, vw = 0~255, e.g. 192.168.100.254 => 81 01 CC 03 0C 00 0A 08 06 04 0F 0E FF
Power_LoadState		8x 01 04 75 6A 02 FF	Load preset 0 when power on
		8x 01 04 75 6A 03 FF	Load Last status when power on
PanTilt_Control_Device		8x 01 7E 03 01 0p FF	p: 0 Encoder 1: Controller
PanTilt_Preset_Speed		8x 01 7E 03 02 0p FF	p: 0: [5 deg/sec] 、 1: [25 deg/sec] 、 2: [50 deg/sec] 、 3: [80 deg/sec] 、 4: [120 deg/sec] 、 5: [160 deg/sec] 、 6: [200 deg/sec] 、 7: [300 deg/sec]
VISCA_SET_RTSP_MULTICASE	Set RTSP Multicast	8x 01 7E 03 30 0p FF	p: 0~1 , 0: Disable 1: Enable
VISCA_SET_IPRATIO1	Set IP Ratio1	8x 01 7E 03 31 0p 0q FF	Set IP Ratio1, pq(HEX) = 1 ~ 60, Example: Set IPRatio1 to 60 => 81 01 7E 03 31 03 0C FF
VISCA_SET_IPRATIO2	Set IP Ratio2	8x 01 7E 03 32 0p 0q FF	Set IP Ratio2, pq(HEX) = 1 ~ 30, Example: Set IPRatio2 to 30 => 81 01 7E 03 32 01 0E FF
VISCA_SET_REBOOT	Set Reboot	8x 01 7E 74 FF	Set to reboot

## 10. Inquiry Command List

Inquiry Command	Command Packet	Inquiry Packet	Comments
CAM_PowerInq	8x 09 04 00 FF	y0 50 02 FF	On
		y0 50 03 FF	Off (Standby)
CAM_OpticalZoomPosInq	8x 09 04 47 FF	y0 50 0p 0q 0r 0s FF	pqrs: Zoom Position , pqrs: 0x0000~0x4000
CAM_FocusModelInq	8x 09 04 38 FF	y0 50 02 FF	Auto Focus
		y0 50 03 FF	Manual Focus
CAM_FocusPosInq	8x 09 04 48 FF	y0 50 0p 0q 0r 0s FF	pqrs: Focus Position, pqrs: parameters are in the General Zoom Foucs Table near end to far end
AF SensitivityInq	8x 09 04 58 FF	y0 50 01 FF	High
		y0 50 02 FF	Middle
		y0 50 03 FF	Low
Resolution SetttngInq	8x 09 06 23 FF	y0 50 0p FF	p: 0x00:1080p-60 0x01:1080p-59.94 0x02:1080p-50 0x03:1080p-30 0x04:1080p-29.97 0x05:1080p-25 0x06:1080i-60 0x07:1080i-59.94 0x08:1080i-50 0x09:720p-60 0x0A:720p-59.94 0x0B:720p-50
CAM_WBModelInq	8x 09 04 35 FF	y0 50 00 FF	Auto
		y0 50 01 FF	In Door

Inquiry Command	Command Packet	Inquiry Packet	Comments
		y0 50 02 FF	Out Door
		y0 50 03 FF	One Push WB
		y0 50 04 FF	ATW
		y0 50 05 FF	Manual
		y0 50 06 FF	Sodium Lamp
		y0 50 07 FF	3000K
		y0 50 08 FF	4300K
		y0 50 09 FF	5000K
		y0 50 0A FF	6500K
		y0 50 0B FF	8000K
		y0 50 0C FF	Wide Auto
CAM_RGainInq	8x 09 04 43 FF	y0 50 00 00 0p 0q FF	pq : R Gain, pq: 00 To 80
CAM_BGainInq	8x 09 04 44 FF	y0 50 00 00 0p 0q FF	pq : B Gain, pq: 00 To 80
CAM_AEModeInq	8x 09 04 39 FF	y0 50 00 FF	Full Auto
		y0 50 03 FF	Manual
		y0 50 0A FF	Shutter Priority
		y0 50 0B FF	Iris Priority
CAM_ShutterPosInq	8x 09 04 4A FF	y0 50 00 00 0p 0q FF	pq: Shutter Position, pq: 00 To 15
CAM_IrisPosInq	8x 09 04 4B FF	y0 50 00 00 0p 0q FF	pq: Iris Position, pq: 06 To 0E
CAM_GainPosInq	8x 09 04 4C FF	y0 50 00 00 0p 0q FF	pq: Gain Position, pq: 00 To 0F
CAM_IrisLimitInq	8x 09 04 2B FF	y0 50 0q FF	p: Gain Limit,p: 3 To 7
CAM_GainLimitInq	8x 09 04 2C FF	y0 50 0q FF	p: Gain Limit,p: 3 To F
CAM_ExpCompPosInq	8x 09 04 4E FF	y0 50 00 00 0p 0q FF	pq: ExpComp Position, pq: 00 To 0B
CAM_WDModeInq	8x 09 04 3D FF	y0 50 02 FF	On
		y0 50 03 FF	Off

Inquiry Command	Command Packet	Inquiry Packet	Comments
CAM_WDParameterInq	8x 09 04 2D FF	y0 50 0p FF	p: WDR mode (p: 0 To 5)
CAM_ApertureInq	8x 09 04 42 FF	y0 50 00 00 0p 0q FF	pq: Aperture Gain, pq: 00 To 0F
CAM_HRModelInq	8x 09 04 52 FF	y0 50 02 FF	On (Hi-Resolution)
		y0 50 03 FF	Off
CAM_2DNRModelInq	8x 09 04 53 FF	y0 50 0p FF	p: NR Setting , p: 0 To 6 (0: Auto,1:Off 6: Max )
CAM_3DNRModelInq	8x 09 04 54 FF	y0 50 0p FF	p: NR Setting , p: 0:Off 1:Low 2:Typ 3:Max 4:Auto
CAM_GammaInq	8x 09 04 5B FF	y0 50 0p FF	Gamma p: 0 To 3
CAM_LR_ReverseModelInq	8x 09 04 61 FF	y0 50 02 FF	On
		y0 50 03 FF	Off
CAM_FreezeModelInq	8x 09 04 62 FF	y0 50 02 FF	On
		y0 50 03 FF	Off
CAM_PictureEffectModelInq	8x 09 04 63 FF	y0 50 00 FF	Off
		y0 50 02 FF	Neg.Art
		y0 50 04 FF	B&W
CAM_PictureFlipModelInq	8x 09 04 66 FF	y0 50 02 FF	On
		y0 50 03 FF	Off
CAM_MemoryInq	8x 09 04 3F FF	y0 50 pp FF	pp: Memory number recalled last, default value(no get any recall command) pp:0x00 To 0x7F
CAM_MuteModelInq	8x 09 04 75 FF	y0 50 02 FF	On
		y0 50 03 FF	Off
CAM Version Inq	8x 09 00 02 FF	y0 50 pp qq rr ss jj kk FF	ppqq: Vender ID,rrss: Model ID,jjjj: Rom revision,kk: Maxinum socket
SYS_MenuModelInq	8x 09 06 06 FF	y0 50 02 FF	On
		y0 50 03 FF	Off
IR_Receive	8x 09 06 08 FF	y0 50 02 FF	On

Inquiry Command	Command Packet	Inquiry Packet	Comments
		y0 50 03 FF	Off
IR_ReceiveReturn	8x 01 7D 01 03 00 00 FF (IR_Receive Return Message On)	y0 07 7D 01 04 00 FF	Power ON/OFF
		y0 07 7D 01 04 07 FF	Zoom tele/wide
		y0 07 7D 01 04 38 FF	AF On/Off
		y0 07 7D 01 04 33 FF	CAM_Backlight
		y0 07 7D 01 04 3F FF	CAM_Memory(All memory set)
		y0 07 7D 01 06 01 FF	Pan_tiltDrive
Pan-tiltMaxSpeedInq	8x 09 06 11 FF	y0 50 ww zz FF	ww = Pan Max Speed, ww: 0x18 zz = Tilt Max Speed, zz: 0x18
Pan-tiltPosInq	8x 09 06 12 FF	y0 50 0w 0w 0w 0w 0z 0z 0z 0z FF	www: Pan Position: 0x0000 to 0x6A40 & 0x95C0 to 0xFFFF (center 0000) zzzz: Tilt Position: 0x0000 to 0x3840 & 0xED40 to 0xFFFF (center 0000)
CAM Image ModeInq	8x 09 04 3F 04 FF	y0 50 0p FF	p: 0-5 = Mode 1-6; p: 6 = Custom mode
Prompt Inq	8x 09 04 07 00 FF	y0 50 02 FF	On
		y0 50 03 FF	Off
CAM SERIAL INQ	8x 09 02 18 FF	y0 50 aa bb cc dd ee ff gg hh ii FF	aa bb cc dd ee ff gg hh ii : Serial Number (ASCII)
CAM_AF Speed Inq	8x 09 04 56 FF	y0 50 02 FF	Normal
		y0 50 03 FF	Fast
BlackLevelInq	8x 09 04 75 69 FF	y0 50 0p FF	p: 0 to 5, 0:Off, 1:Type 1, 2:Type 2, 3:Type 3,4:Type 4,5:Type 5
Pan speed table inq	8x 09 06 1A 0p 0q FF	y0 50 0p 0q 0r 0s FF	pq: 0x0 ~ 0x63, pqs: 0x0 ~ 0xFFFF
Tilt speed table inq	8x 09 06 1B 0p 0q FF	y0 50 0p 0q 0r 0s FF	pq: 0x0 ~ 0x63, pqs: 0x0 ~ 0xFFFF
Model name inq	0x 09 04 3C FF	y0 50 aa bb cc dd ee ff gg hh ii kk FF	aa bb cc dd ee ff gg hh ii kk (ascii code)

RS158 - VC-A51P\_VC-A51PN RS-232 command set

Inquiry Command	Command Packet	Inquiry Packet	Comments
Tally Mode Inq	8x 09 7E 01 0A 01 FF	y0 50 0p FF	p: 0: (Power LED:Green Standby:OFF) 5: (Power LED:Red Standby:Red) - Tally Lamp must be Enabled 6: (Power LED: Green Standby:Red) - Tally Lamp must be Enabled 7: (Power LED: OFF Standby:OFF) - Tally Lamp must be Enabled
Tally Lamp Inq	8x 09 7E 01 0A 00 FF	y0 50 0p FF	p: 2 Enable 3: Disable
CAM_ColorGainInq	8x 09 04 49 FF	y0 50 00 00 00 pq FF	pq: Color Gain setting , pq: 0x00 To 0x19
CAM_Skin_ToneInq	8x 09 04 75 06 FF	y0 50 0p FF	p: 0~5
CAM_IP_Addr_Inq	8x 09 04 02 FF	y0 50 pq rs tu vw FF	address : pq.rs.tu.vw (HEX), pq = 0~255, rs = 0~255, tu = 0~255, vw = 0~255, e.g. 192.168.100.150 => 90 50 C0 A8 64 96 FF
CAM_Subnet_Mask_Inq	8x 09 04 03 FF	y0 50 pq rs tu vw FF	address : pq.rs.tu.vw (HEX), pq = 0~255, rs = 0~255, tu = 0~255, vw = 0~255, e.g. 255.255.255.0 => 90 50 FF FF FF 00 FF
CAM_Gateway_Inq	8x 09 04 04 FF	y0 50 pq rs tu vw FF	address : pq.rs.tu.vw (HEX), pq = 0~255, rs = 0~255, tu = 0~255, vw = 0~255, e.g. 192.168.100.254 => 90 50 C0 A8 64 FE FF
CAM OPT ZOOM LIMIT INQ	8x 09 04 34 43 FF	y0 50 0a 0b FF	ab: 0 ~ 0x13
CAM MF TRACKING INQ	8x 09 04 32 23 FF	y0 05 0a FF	a: 0(OFF) 、 1(ON)
Power_LoadStateInq	8x 09 04 75 6A FF	y0 50 02 FF	Load preset 0 when power on
		y0 50 03 FF	Load Last status when power on
Custom_BrightnessInq	8x 09 04 75 67 FF	y0 50 pq FF	pq: 0x0 ~0x19
Custiom_Contrast	8x 09 04 75 68 FF	y0 50 pq FF	pq:0x0 ~ 0x19
PanTilt_Control_Device_Inq	8x 09 04 75 31 FF	y0 50 0p FF	p: 0 Encoder 1: Controller

Inquiry Command	Command Packet	Inquiry Packet	Comments
PanTilt_Preset_Speed_Inq	8x 09 04 75 32 FF	y0 50 0p FF	p: 0: [5 deg/sec] 、 1: [25 deg/sec] 、 2: [50 deg/sec] 、 3: [80 deg/sec] 、 4: [120 deg/sec] 、 5: [160 deg/sec] 、 6: [200 deg/sec] 、 7: [300 deg/sec]
CAM_IPRatio1_Inq	8x 09 04 08 FF	y0 50 pq FF	pq: IPRatio1(Hex), ex. IPRatio1 : 60 => 90 50 3C FF
CAM_IPRatio2_Inq	8x 09 04 09 FF	y0 50 pq FF	pq: IPRatio2(Hex), ex. IPRatio2 : 30 => 90 50 1E FF
RTSP_Multicase_Inq	8x 09 04 10 FF	y0 50 0p FF	p: 0~1 , 0: Disable 1: Enable

# 11. Camera Block Inquiry Command List

## 18.1 Lens Control System Inquiry Commands.....Command Set 8x 09 7E 7E 00 FF

Byte	Bit	Comments
Byte0	0	Source Address
	1	
	2	
	3	
	4	Destination Address
	5	
	6	
	7	
Byte1	0	0
	1	0
	2	0
	3	0
	4	1
	5	0
	6	1
	7	0
Byte2	0	Zoom Position (HH)
	1	
	2	
	3	
	4	0
	5	0
	6	0
	7	0

Byte	Bit	Comments
Byte3	0	Zoom Position (HL)
	1	
	2	
	3	
	4	0
	5	0
	6	0
	7	0
Byte4	0	Zoom Position (LH)
	1	
	2	
	3	
	4	0
	5	0
	6	0
	7	0
Byte5	0	Zoom Position (LL)
	1	
	2	
	3	
	4	0
	5	0
	6	0
	7	0

Byte	Bit	Comments
Byte6	0	0
	1	0
	2	0
	3	0
	4	0
	5	0
	6	0
	7	0
Byte7	0	0
	1	0
	2	0
	3	0
	4	0
	5	0
	6	0
	7	0
Byte8	0	Focus Position (HH)
	1	
	2	
	3	
	4	0
	5	0
	6	0
	7	0



Byte	Bit	Comments
Byte9	0	Focus Position (HL)
	1	
	2	
	3	
	4	0
	5	0
	6	0
	7	0
Byte10	0	Focus Position (LH)
	1	
	2	
	3	
	4	0
	5	0
	6	0
	7	0
Byte11	0	Focus Position (LL)
	1	
	2	
	3	
	4	0
	5	0

Byte	Bit	Comments
	6	0
	7	0
Byte12	0	0
	1	0
	2	0
	3	0
	4	0
	5	0
	6	0
	7	0
Byte13	0	Focus Mode 0: Manual 1: Auto
	1	0
	2	0
	3	0
	4	0
	5	0

Byte	Bit	Comments
	6	0
	7	0
Byte14	0	Zoom Command 1: Executing 0: Stopped
	1	Focus Command 1: Executing 0: Stopped
	2	Camera Memory Recall 1: Executing 0: Stopped
	3	0
	4	0
	5	0
	6	0
	7	0
Byte15	0	1
	1	1
	2	1
	3	1
	4	1
	5	1
	6	1
	7	1

### 18.2 Camera Control System Inquiry Commands.....Command Set 8x 09 7E 7E 01 FF

Byte	Bit	Comments
Byte0	0	Source Address
	1	
	2	
	3	
	4	Destination Address
	5	
	6	
	7	
Byte1	0	0
	1	0
	2	0
	3	0
	4	1
	5	0
	6	1
	7	0
Byte2	0	R Gain (H)
	1	
	2	
	3	
	4	0
	5	0
	6	0
	7	0

Byte	Bit	Comments
Byte3	0	R Gain (L)
	1	
	2	
	3	
	4	0
	5	0
	6	0
	7	0
Byte4	0	B Gain (H)
	1	
	2	
	3	
	4	0
	5	0
	6	0
	7	0
Byte5	0	B Gain (L)
	1	
	2	
	3	
	4	0
	5	0
	6	0
	7	0

Byte	Bit	Comments
Byte6	0	WB Mode
	1	
	2	
	3	
	4	0
	5	0
	6	0
	7	0
Byte7	0	Aperture Gain
	1	
	2	
	3	
	4	0
	5	0
	6	0
	7	0
Byte8	0	Exposure Mode
	1	
	2	
	3	
	4	0
	5	0
	6	0
	7	0

Byte	Bit	Comments
Byte9	0	0
	1	Exposure Comp. 1: On 0: Off
	2	Back Light 1: On 0: Off
	3	0
	4	WDR 0:Off 1:On
	5	High-Resolution 1: On 0: Off
	6	0
	7	0
Byte10	0	Shutter Position
	1	
	2	
	3	
	4	
	5	
	6	0
	7	0

Byte	Bit	Comments
Byte11	0	Iris Position
	1	
	2	
	3	
	4	
	5	0
	6	0
	7	0
Byte12	0	Gain Position
	1	
	2	
	3	
	4	
	5	0
	6	0
	7	0
Byte13	0	Bright Position
	1	
	2	
	3	
	4	
	5	0
	6	0
	7	0

Byte	Bit	Comments
Byte14	0	Exposure Comp. Position
	1	
	2	
	3	
	4	0
	5	0
	6	0
	7	0
Byte15	0	1
	1	1
	2	1
	3	1
	4	1
	5	1
	6	1
	7	1

**18.3 Other Inquiry Commands.....Command Set 8x 09 7E 7E 02 FF**

Byte	Bit	Comments
Byte0	0	Source Address
	1	
	2	
	3	
	4	Destination Address
	5	
	6	
	7	
Byte1	0	0
	1	0
	2	0
	3	0
	4	1
	5	0
	6	1
	7	0
Byte2	0	Power 1: On 0: Off
	1	0
	2	0
	3	0
	4	0
	5	0
	6	0
	7	0

Byte	Bit	Comments
Byte3	0	0
	1	0
	2	LR Reverse 1: On 0: Off
	3	Freeze 1: On 0: Off
	4	ICR 1: On 0: Off
	5	0
	6	0
	7	0
Byte4	0	0
	1	0
	2	0
	3	0
	4	Mute 1: On 0: Off
	5	0
	6	0
	7	0
Byte5	0	Picture Effect Mode
	1	
	2	
	3	
	4	0
	5	0
	6	0
	7	0

Byte	Bit	Comments
Byte6	0	0
	1	0
	2	0
	3	0
	4	0
	5	0
	6	0
	7	0
Byte7	0	0
	1	0
	2	0
	3	0
	4	0
	5	0
	6	0
	7	0
Byte8	0	Camera ID (HH)
	1	
	2	
	3	
	4	0
	5	0
	6	0
	7	0

Byte	Bit	Comments
Byte9	0	Camera ID (HL)
	1	
	2	
	3	
	4	0
	5	0
	6	0
	7	0
Byte10	0	Camera ID (LH)
	1	
	2	
	3	
	4	0
	5	0
	6	0
	7	0
Byte11	0	Camera ID (LL)

Byte	Bit	Comments
	1	
	2	
	3	
	4	
	5	0
	6	0
	7	0
Byte12	0	System 1:1/50, 1/25 0:1/59.94, 1/29.97
	1	0
	2	ICR 1: Provided 0: Not provided
	3	0
	4	Memory 1: Provided 0: Not provided
	5	0
	6	0
	7	0
Byte13	0	0
	1	0
	2	0

Byte	Bit	Comments	
	3	0	
	4	0	
	5	0	
	6	0	
	7	0	
	Byte14	0	0
		1	0
2		0	
3		0	
4		0	
5		0	
6		0	
7		0	
Byte15	0	1	
	1	1	
	2	1	
	3	1	
	4	1	
	5	1	
	6	1	
	7	1	

**18.4 Enlargement Function1 Query Command.....Command Set 8x 09 7E 7E 03 FF**

Byte	Bit	Comments
Byte0	0	Source Address
	1	
	2	
	3	
	4	Destination Address
	5	
	6	
7		
Byte1	0	0
	1	0
	2	0
	3	0
	4	1
	5	0
	6	1
	7	0
Byte2	0	0
	1	0
	2	0
	3	0
	4	0
	5	0
	6	0
	7	0

Byte	Bit	Comments
Byte3	0	0
	1	0
	2	0
	3	0
	4	0
	5	0
	6	0
	7	0
Byte4	0	0
	1	0
	2	0
	3	0
	4	0
	5	0
	6	0
	7	0
Byte5	0	0
	1	0
	2	0
	3	0
	4	0
	5	0
	6	0
	7	0

Byte	Bit	Comments
Byte6	0	0
	1	0
	2	0
	3	0
	4	0
	5	0
	6	0
Byte7	0	0
	1	0
	2	0
	3	0
	4	0
	5	0
	6	0
Byte8	0	0
	1	
	2	
	3	0
	4	
	5	
	6	
7	0	

Byte	Bit	Comments
Byte9	0	0
	1	0
	2	0
	3	0
	4	0
	5	0
	6	0
	7	0
Byte10	0	Flip (1: On, 0: Off )
	1	Alarm (1: On, 0: Off )
	2	0
	3	0
	4	0
	5	0
	6	0
	7	0
Byte11	0	Flip (1: Provided, 0: Not provided)
	1	0

Byte	Bit	Comments	
	2	Advanced Privacy (1: Provided, 0: Not provided)	
	3	Color Gain (0h (60%) to Eh (200%))	
	4		
	5		
	6		
	7	0	
	Byte12	0	0
		1	0
2		0	
3		0	
4		0	
5		0	
6		0	
7		0	
Byte13	0	2DNR Level	
	1		

Byte	Bit	Comments
	2	High Sensitivity mode (1: ON, 0: OFF)
	3	
	4	
	5	Gamma
	6	
	7	0
	Byte14	0
1		
2		
3		0
4		
5		
6		
7	0	
Byte15	0	1
	1	1
	2	1
	3	1
	4	1
	5	1
	6	1
	7	1

**18.5 Enlargement Function2 Query Command.....Command Set 8x 09 7E 7E 04 FF**

Byte	Bit	Comments
Byte0	0	Source Address
	1	
	2	
	3	
	4	Destination Address
	5	
	6	
	7	
Byte1	0	0
	1	0
	2	0
	3	0
	4	1
	5	0
	6	1
	7	0
Byte2	0	WDR Index
	1	
	2	
	3	0
	4	0
	5	0
	6	0
	7	0

Byte	Bit	Comments
Byte3	0	0
	1	0
	2	0
	3	0
	4	0
	5	0
	6	0
	7	0
Byte4	0	0
	1	0
	2	0
	3	0
	4	0
	5	0
	6	0
	7	0
Byte5	0	0
	1	0
	2	0
	3	0
	4	0
	5	0
	6	0
	7	0

Byte	Bit	Comments
Byte6	0	0
	1	0
	2	0
	3	0
	4	0
	5	0
	6	0
	7	0
Byte7	0	0
	1	0
	2	0
	3	0
	4	0
	5	0
	6	0
	7	0
Byte8	0	0
	1	0
	2	0
	3	0
	4	0
	5	0
	6	0
	7	0



Byte	Bit	Comments
Byte9	0	0
	1	0
	2	0
	3	0
	4	0
	5	0
	6	0
	7	0
Byte10	0	0
	1	0
	2	0
	3	0
	4	0
	5	0
	6	0
	7	0

Byte	Bit	Comments
Byte11	0	0
	1	0
	2	0
	3	0
	4	0
	5	0
	6	0
	7	0
Byte12	0	0
	1	0
	2	0
	3	0
	4	0
	5	0
	6	0
	7	0

Byte	Bit	Comments
Byte13	0	0
	1	0
	2	0
	3	0
	4	0
	5	0
	6	0
	7	0
Byte14	0	0
	1	0
	2	0
	3	0
	4	0
	5	0
	6	0
	7	0
Byte15	0	1
	1	1
	2	1
	3	1
	4	1
	5	1
	6	1
	7	1

**18.6 Enlargement Function3 Query Command.....Command Set 8x 09 7E 7E 05 FF**

Byte	Bit	Comments
Byte0	0	Source Address
	1	
	2	
	3	
	4	Destination Address
	5	
	6	
	7	
Byte1	0	0
	1	0
	2	0
	3	0
	4	1
	5	0
	6	1
	7	0
Byte2	0	0
	1	0
	2	0
	3	0
	4	0
	5	0
	6	0
	7	0

Byte	Bit	Comments
Byte3	0	0
	1	0
	2	0
	3	0
	4	0
	5	0
	6	0
	7	0
Byte4	0	0
	1	0
	2	0
	3	0
	4	0
	5	0
	6	0
	7	0
Byte5	0	0
	1	0
	2	0
	3	0
	4	0
	5	0
	6	0
	7	0

Byte	Bit	Comments
Byte6	0	0
	1	0
	2	0
	3	0
	4	0
	5	0
	6	0
	7	0
Byte7	0	0
	1	0
	2	0
	3	0
	4	0
	5	0
	6	0
	7	0
Byte8	0	0
	1	0
	2	0
	3	0
	4	0
	5	0
	6	0
	7	0

Byte	Bit	Comments
Byte9	0	0
	1	0
	2	0
	3	0
	4	0
	5	0
	6	0
	7	0
Byte10	0	0
	1	0
	2	0
	3	0
	4	0
	5	0
	6	0
	7	0

Byte	Bit	Comments
Byte11	0	0
	1	0
	2	0
	3	0
	4	0
	5	0
	6	0
	7	0
Byte12	0	0
	1	0
	2	0
	3	0
	4	0
	5	0
	6	0
	7	0

Byte	Bit	Comments
Byte13	0	0
	1	0
	2	0
	3	0
	4	0
	5	0
	6	0
	7	0
Byte14	0	0
	1	0
	2	0
	3	0
	4	0
	5	0
	6	0
	7	0
Byte15	0	1
	1	1
	2	1
	3	1
	4	1
	5	1
	6	1
	7	1

## **12. RS232 over IP**

### **19.1 Overview of RS232 over IP**

RS232 over IP allows you to control this unit from the controller with the IP communication function via the LAN by using RS232.

You can connect up to 5 controllers simultaneously on one LAN segment.

The communication specifications of RS232 over IP are as follows:

### **19.2 Interface**

RJ-45 10Base-T/100Base-TX (automatically discrimination)

### **19.3 Internet protocol**

IPv4

### **19.4 Transport protocol**

UDP

### **19.5 IP address**

Set by the IP card setting command

### **19.6 Port address**

52381

### **19.7 Delivery confirmation/Retransmission control**

Depends on the application

### **19.8 Coverage**

Limited dedicated network in the same segment without going through a bridge connection.

In this section, the device outputting commands, for example, a computer, is called the controller, and this unit and the devices connected to the same LAN are called the peripheral device. In the connection using RS-232/RS-422, the controllers and peripheral devices are connected to a one-direction ring. On the IP communication connection, the controllers and peripheral devices are connected by star type through a LAN.

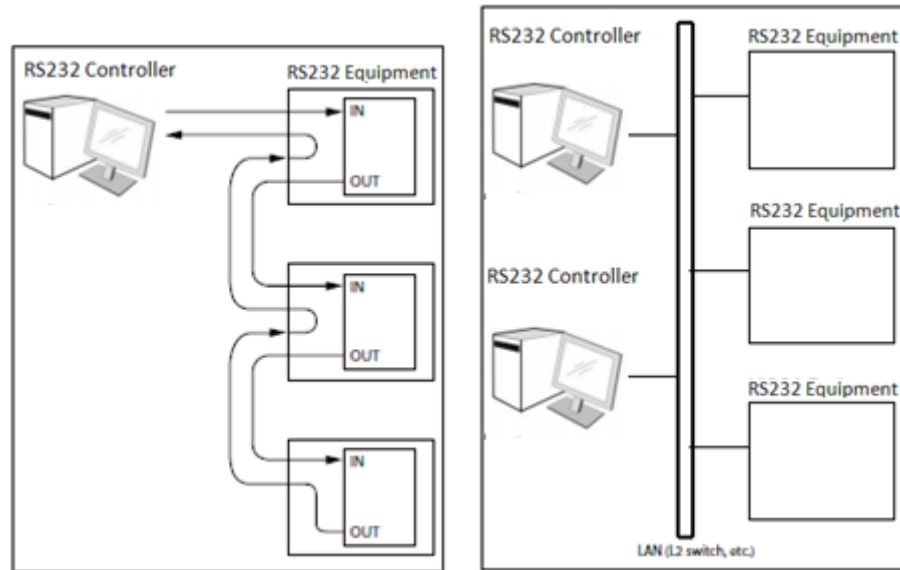

**RS232/RS422 connection**

**IP communication connection**

While the IP communication connection, the address of each device cannot be set in the RS232 message as it is because the controllers and peripheral devices that are connected simultaneously are increased. In this case, addresses of the controllers and peripheral devices that are set in the RS232 message are locked to 0 (for the controller) or 1 (for the peripheral device).

### 19.9 Packet Structure

The basic unit of VISCA communication is called a packet [Pic.1]. The first byte of the packet is called the header and comprises the sender's and receiver's addresses. For example, the header of the packet sent to the SRG assigned address 1 from the controller (address 0) is 81h in hexadecimal. The packet sent to the SRG assigned address 2 is 82h. In the command list, as the header is 8X, input the address of the SRG to X. The header of the reply packet from the SRG assigned address 1 is 90h. The packet from the SRG assigned address 2 is A0h.

Some of the setting commands for SRG can be sent to all devices at one time (broadcast)\*. In the case of broadcast, the header should be 88h in hexadecimal.

When the terminator is FFh, it signifies the end of the packet.

\*The broadcast function is not available for VISCA over IP.

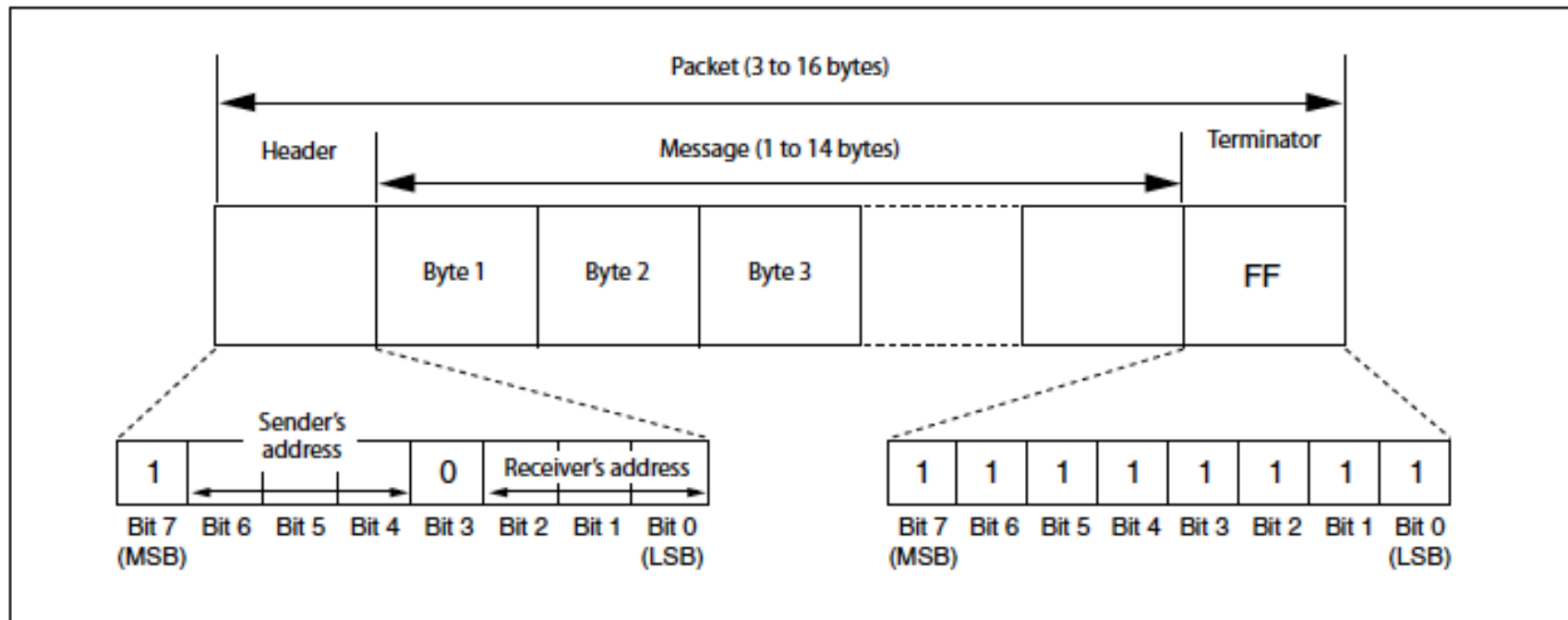

Pic. 1 Packet structure

Note:

Pic. 1 shows the packet structure, while Pic.2 shows the actual waveform. Data flow will take place with the LSB first.

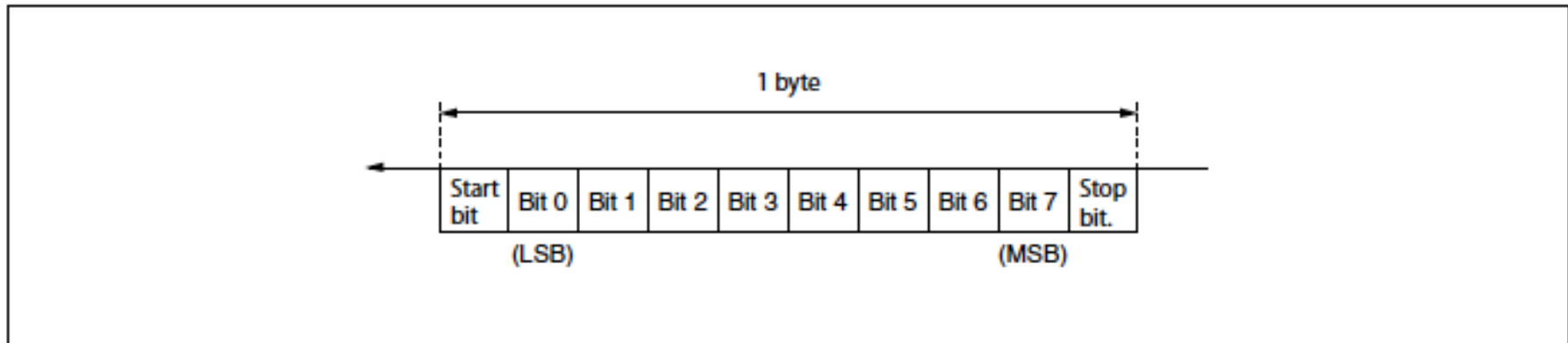

Pic. 2 Actual waveform for 1 byte

### 13. Communication method of VISCA over IP

#### 20.1 Communication method

VISCA over IP can process the VISCA communication between the controllers and peripheral devices using the messages that can be identified on the LAN, and sends/receives them. Because of this, VISCA over IP is not concerned about the contents of the communication between the controllers and peripheral devices. However, the VISCA communication sequence is different, depending on the types, as follows.

#### 20.2 VISCA command

This is a command from the controller to the peripheral device. When the peripheral device receives this command, Acknowledge is returned. After completing command processing, a completion notice is returned. This command uses the socket of VISCA. The order of completion notices may be changed if the multiple commands are sent to the same peripheral device.

#### 20.3 VISCA inquiry

This is an inquiry from the controller to the peripheral device. When the peripheral device receives this type of command, the reply for the inquiry is returned. This command does not use the socket of VISCA. The order of the replies is not changed if a multiple commands are sent.

#### **20.4 VISCA reply**

This is an Acknowledge, completion notice, reply, or error reply from the peripheral device to the controller. The classification for sending messages from the peripheral device to the controller is common.

#### **20.5 VISCA device setting command**

This is the device setting command from the controller to the peripheral device. When the peripheral device receives this classification command, the peripheral device performs the function depend on the command.

#### **20.6 Address**

Sets the address of the peripheral device, and does not return a reply to the controller. While using VISCA over IP, the address command is not sent from the controller because a Network Change command from the peripheral device that triggers sending command is not issued.

#### **20.7 IF\_Clear**

Sends the reply message to the controller after clearing, without using VISCA socket.

#### **20.8 CAM\_VerslonInq**

Sends the reply message to the controller, without using VISCA socket.

#### **20.9 Format**

These are the specifications of the message header (8 bytes) and payload (1 to 16 bytes).



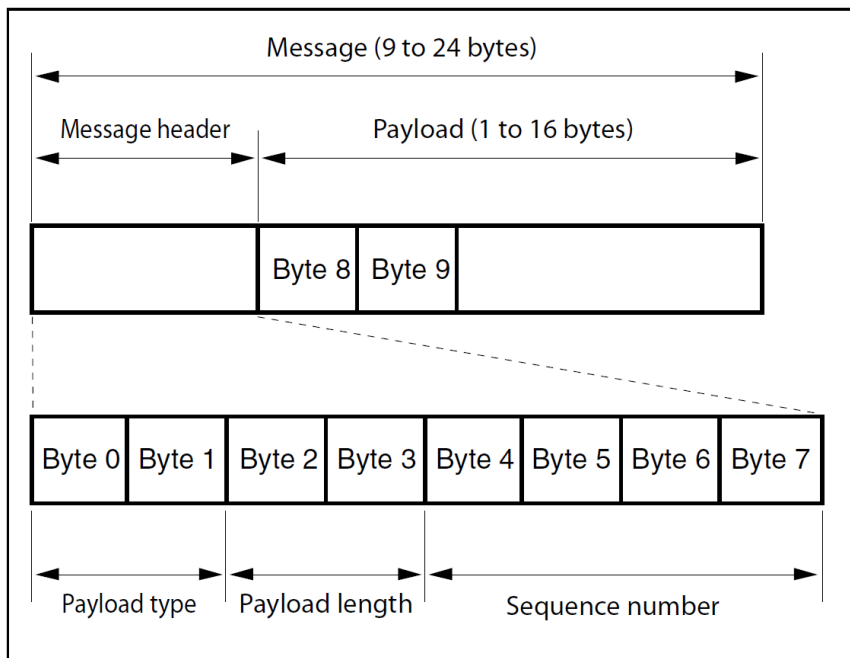

Note: The actual LAN out method is big-endian, LSB first.

Pic.3 Message structure of the VISCA over IP

Example:

Command	Payload type		Payload length		Sequence number				Payload (1~16Byte)										
	Byte 0	Byte 1	Byte 2	Byte 3	Byte 4	Byte 5	Byte 6	Byte 7	Byte 1	Byte 2	Byte 3	Byte 4	Byte 5	Byte 6	Byte 7	Byte 8	Byte 9	...	Byte 16
CAM_Power On	01	00	00	06	00	00	00	01	81	01	04	00	02	FF					
Pan-tiltDrive Up	01	00	00	09	00	00	00	02	81	01	06	01	0C	0C	03	01	FF		
Pan-tiltDrive Down	01	00	00	09	00	00	00	03	81	01	06	01	0C	0C	03	02	FF		
CAM_FocusModelInq	01	10	00	5	00	00	00	04	81	9	4	38	FF						

## 20.10 Payload type

Stores the value (Byte 0 and Byte 1) of the following table on the payload division.

Name	Value (Byte 0)	Value (Byte 1)	Description
VISCA command	01h	00h	Stores the VISCA command.
VISCA inquiry	01h	10h	Stores the VISCA inquiry.
VISCA reply	01h	11h	Stores the reply for the VISCA command and VISCA inquiry, or VISCA device setting command.
VISCA device setting command	01h	20h	Stores the VISCA device setting command.
Control command	02h	00h	Stores the control command.
Control reply	02h	01h	Stores the reply for the control command.

Pic.4 Payload Type Table

### 20.11 Payload length

Stores the number of bytes (1 to 16) of data is stored on the payload.

Example: when the payload length is 16 bytes.

Byte 2:00h

Byte 3:10h

### 20.12 Sequence number

The controller stores the sequence number that is added every time a message is sent. If the sequence number reaches the limit, next values will be 0. The peripheral device saves the sequence number in the message from the controller, and stores the sequence number of the received message corresponding to the message sent to the controller.

### 20.13 Payload

Depending on the payload type, the following are stored.

- VISCA command
  - Stores the packet of the VISCA command.
- VISCA inquiry
  - Stores the packet of VISCA message.
- VISCA reply
  - Stores the reply for the command or inquiry (Acknowledge message, completion message, or error message).
- VISCA device setting command

- Stores the packet of the VISCA device setting command.
- Control command
  - The following are stored on the payload division of the control command.

Name	Value	Description
RESET	01h	Resets the sequence number to 0. The value that was set as the sequence number is ignored.
ERROR	0Fyyh	yy=01: Abnormality in the sequence number.
		yy=02: Abnormality in the message (message type)

- Controlled reply
  - The following are stored on the payload division of the reply for the control command.

Message	Value	Description
Acknowledge	01h	Reply for RESET.

#### 20.14 Delivery confirmation

VISCA over IP uses UDP as a communications protocol of the transport layer. Delivery of messages is not guaranteed for the UDP communication. Delivery confirmation and retransmission should be performed on the application.

When the controller sends a message to the peripheral device, wait until a reply for the message is received before sending the next message. You can confirm delivery of messages by managing the time-out waiting for a reply message sent.

If time out occurs on the controller, loss of one of the following message is considered:

- Command
- Acknowledge message
- Completion message for command
- Inquiry
- Reply message for the inquiry

- **Error message**
- **Inquiry of the VISCA device setting command**
- **Reply message of the VISCA device setting command.**

## 14. PelcoD Internal Command List

Internal Command	Byte 1	Byte 2 (Address)	Byte 3	Byte 4	Byte 5	Byte 6	Byte 7	Comments
Right	0xFF	0x00 ~ 0xFF	0x00	0x02	0xVV	0xWW	Checksum	VV : Tilt speed 0x01 (low speed) to 0x18 (high speed) WW : Pan speed 0x01 (low speed) to 0x18 (high speed)
Left	0xFF	0x00 ~ 0xFF	0x00	0x04	0xVV	0xWW	Checksum	
Up	0xFF	0x00 ~ 0xFF	0x00	0x08	0xVV	0xWW	Checksum	
Down	0xFF	0x00 ~ 0xFF	0x00	0x10	0xVV	0xWW	Checksum	
Right - Up	0xFF	0x00 ~ 0xFF	0x00	0x0A	0xVV	0xWW	Checksum	
Left - Up	0xFF	0x00 ~ 0xFF	0x00	0x0C	0xVV	0xWW	Checksum	
Right -Down	0xFF	0x00 ~ 0xFF	0x00	0x12	0xVV	0xWW	Checksum	
Left - Down	0xFF	0x00 ~ 0xFF	0x00	0x14	0xVV	0xWW	Checksum	
Zoom Tele Down	0xFF	0x00 ~ 0xFF	0x00	0x30	0xVV	0xWW	Checksum	
Zoom Tele Up	0xFF	0x00 ~ 0xFF	0x00	0x28	0xVV	0xWW	Checksum	
Zoom Tele Left	0xFF	0x00 ~ 0xFF	0x00	0x24	0xVV	0xWW	Checksum	
Zoom Tele Right	0xFF	0x00 ~ 0xFF	0x00	0x22	0xVV	0xWW	Checksum	
Zoom Tele Up-Left	0xFF	0x00 ~ 0xFF	0x00	0x2C	0xVV	0xWW	Checksum	
Zoom Tele Up-Right	0xFF	0x00 ~ 0xFF	0x00	0x2A	0xVV	0xWW	Checksum	
Zoom Tele Down-Left	0xFF	0x00 ~ 0xFF	0x00	0x34	0xVV	0xWW	Checksum	
Zoom Tele Down-Right	0xFF	0x00 ~ 0xFF	0x00	0x32	0xVV	0xWW	Checksum	
Zoom Wide Down	0xFF	0x00 ~ 0xFF	0x00	0x50	0xVV	0xWW	Checksum	
Zoom Wide Up	0xFF	0x00 ~ 0xFF	0x00	0x48	0xVV	0xWW	Checksum	
Zoom Wide Left	0xFF	0x00 ~ 0xFF	0x00	0x44	0xVV	0xWW	Checksum	
Zoom Wide Right	0xFF	0x00 ~ 0xFF	0x00	0x42	0xVV	0xWW	Checksum	
Zoom Wide Up-Left	0xFF	0x00 ~ 0xFF	0x00	0x4C	0xVV	0xWW	Checksum	
Zoom Wide Up-Right	0xFF	0x00 ~ 0xFF	0x00	0x4A	0xVV	0xWW	Checksum	
Zoom Wide Down-Left	0xFF	0x00 ~ 0xFF	0x00	0x54	0xVV	0xWW	Checksum	
Zoom Wide Down-Right	0xFF	0x00 ~ 0xFF	0x00	0x52	0xVV	0xWW	Checksum	

Internal Command	Byte 1	Byte 2 (Address)	Byte 3	Byte 4	Byte 5	Byte 6	Byte 7	Comments
FOCUS Far Down	0xFF	0x00 ~ 0xFF	0x00	0x90	0xVV	0xWW	Checksum	VV : Tilt speed 0x01 (low speed) to 0x18 (high speed) WW : Pan speed 0x01 (low speed) to 0x18 (high speed)
FOCUS Far Up	0xFF	0x00 ~ 0xFF	0x00	0x88	0xVV	0xWW	Checksum	
FOCUS Far Left	0xFF	0x00 ~ 0xFF	0x00	0x84	0xVV	0xWW	Checksum	
FOCUS Far Right	0xFF	0x00 ~ 0xFF	0x00	0x82	0xVV	0xWW	Checksum	
FOCUS Far Up-Left	0xFF	0x00 ~ 0xFF	0x00	0x8C	0xVV	0xWW	Checksum	
FOCUS Far Up-Right	0xFF	0x00 ~ 0xFF	0x00	0x8A	0xVV	0xWW	Checksum	
FOCUS Far Down-Left	0xFF	0x00 ~ 0xFF	0x00	0x94	0xVV	0xWW	Checksum	
FOCUS Far Down-Right	0xFF	0x00 ~ 0xFF	0x00	0x92	0xVV	0xWW	Checksum	
FOCUS Near Down	0xFF	0x00 ~ 0xFF	0x01	0x10	0xVV	0xWW	Checksum	
FOCUS Near Up	0xFF	0x00 ~ 0xFF	0x01	0x08	0xVV	0xWW	Checksum	
FOCUS Near Left	0xFF	0x00 ~ 0xFF	0x01	0x04	0xVV	0xWW	Checksum	
FOCUS Near Right	0xFF	0x00 ~ 0xFF	0x01	0x02	0xVV	0xWW	Checksum	
FOCUS Near Up-Left	0xFF	0x00 ~ 0xFF	0x01	0x0C	0xVV	0xWW	Checksum	
FOCUS Near Up-Right	0xFF	0x00 ~ 0xFF	0x01	0x0A	0xVV	0xWW	Checksum	
FOCUS Near Down-Left	0xFF	0x00 ~ 0xFF	0x01	0x14	0xVV	0xWW	Checksum	
FOCUS Near Down-Right	0xFF	0x00 ~ 0xFF	0x01	0x12	0xVV	0xWW	Checksum	
Stop	0xFF	0x00 ~ 0xFF	0x00	0x00	0x00	0x00	Checksum	Stop Pan/Tilt & Zomm/Focus
Zoom Tele	0xFF	0x00 ~ 0xFF	0x00	0x20	0x00	0x00	Checksum	Speed = VISCA Tele (Variable) = 0x03
Zoom Wide	0xFF	0x00 ~ 0xFF	0x00	0x40	0x00	0x00	Checksum	Speed = VISCA Wide (Variable) = 0x03
Focus Far	0xFF	0x00 ~ 0xFF	0x00	0x80	0x00	0x00	Checksum	Speed = VISCA Far (Variable) = 0x02
Focus Near	0xFF	0x00 ~ 0xFF	0x01	0x00	0x00	0x00	Checksum	Speed = VISCA Near (Variable) = 0x02
Checksum = Mod((Byte 2 + Byte 3 + Byte 4 + Byte 5 + Byte 6), 0x100);								

## 15. PelcoD External Command List

### 22.1 External Command

External Command	Byte 1	Byte 2 (Address)	Byte 3	Byte 4	Byte 5	Byte 6	Byte 7	Comments
Set Preset	0xFF	0x00 ~ 0xFF	0x00	0x03	0x00	0xpq	Checksum	Memory Number( pq:0x00 To 0xFF)
Clear Preset	0xFF	0x00 ~ 0xFF	0x00	0x05	0x00	0xpq	Checksum	
Goto Preset	0xFF	0x00 ~ 0xFF	0x00	0x07	0x00	0xpq	Checksum	
POWER	0xFF	0x00 ~ 0xFF	0x00	0x45	0x00	On:0x01 Off: 0x02	Checksum	Power On/Off
MENU	0xFF	0x00 ~ 0xFF	0x00	0x47	0x00	On:0x01 Off: 0x02	Checksum	System Menu On/Off
ENTER	0xFF	0x00 ~ 0xFF	0x00	0x49	0x00	0x00	Checksum	Menu Enter
BACKLIGHT	0xFF	0x00 ~ 0xFF	0x00	0x31	0x00	On:0x01 Off: 0x02	Checksum	Back Light Compensation ON/OFF
MIRROR	0xFF	0x00 ~ 0xFF	0x00	0x4B	0x00	0x01:Normal 0x02:Mirror 0x03:Flip 0x04:Mirror+Flip	Checksum	Mirror Image ON/OFF & Picture flip ON/OFF
FREEZE	0xFF	0x00 ~ 0xFF	0x00	0x4D	0x00	On:0x01 Off: 0x02	Checksum	Still Image ON/OFF
Auto Focus / Manual Focus	0xFF	0x00 ~ 0xFF	0x00	0x2B	0x00	AF:0x01 MF: 0x02	Checksum	AF/MF Switch
Bright Ctrl Up	0xFF	0x00 ~ 0xFF	0x00	0xA1	0x00	0x00	Checksum	AE Bright Control Up
Bright Ctrl Down	0xFF	0x00 ~ 0xFF	0x00	0xA3	0x00	0x00	Checksum	AE Bright Control Down

## 22.2 Query Command

Query Command	Byte 1	Byte 2 (Address)	Byte 3	Byte 4	Byte 5	Byte 6	Byte 7	Comments
<b>Query Command Package</b>								
Query Pan Position	0xFF	0x00 ~ 0xFF	0x00	0x51	0x00	0x00	Checksum	Get Pan Postion
Query Tilt Position	0xFF	0x00 ~ 0xFF	0x00	0x53	0x00	0x00	Checksum	Get Tilt Postion
Query Zoom Position	0xFF	0x00 ~ 0xFF	0x00	0x55	0x00	0x00	Checksum	Get Zoom Position
Query POWER	0xFF	0x00 ~ 0xFF	0x00	0x61	0x00	0x00	Checksum	Get Power On/Off Status
Query MENU	0xFF	0x00 ~ 0xFF	0x00	0x63	0x00	0x00	Checksum	Get Menu On/Off Status
Query BACKLIGHT	0xFF	0x00 ~ 0xFF	0x00	0x65	0x00	0x00	Checksum	Get Backlight On/Off Status
Query MIRROR	0xFF	0x00 ~ 0xFF	0x00	0x67	0x00	0x00	Checksum	Get Mirror & Flip Status
Query FREEZE	0xFF	0x00 ~ 0xFF	0x00	0x69	0x00	0x00	Checksum	Get Freeze Status
<b>Query Ack Package</b>								
Query Pan Response	0xFF	0x00 ~ 0xFF	0x00	0x59	0x pq	0x rz	Checksum	pqrz: Pan Position 0x0000 to 0x06A4 & 0xF95C to 0xFFFF (center 0000)
Query Tilt Response	0xFF	0x00 ~ 0xFF	0x00	0x5B	0x pq	0x rz	Checksum	pqrz: Tilt Position 0x0000 to 0x0384 & 0xFED4 to 0xFFFF (center 0000)
Query Zoom Response	0xFF	0x00 ~ 0xFF	0x00	0x5D	0x pq	0x rz	Checksum	pqrs: Zoom Position , pqrs: 0x0000~0x4000
Query POWER Response	0xFF	0x00 ~ 0xFF	0x00	0x71	0x00	On:0x01 Off: 0x02	Checksum	Power Status Response
Query MENU Response	0xFF	0x00 ~ 0xFF	0x00	0x73	0x00	On:0x01 Off: 0x02	Checksum	Menu Status Response
Query BACKLIGHT	0xFF	0x00 ~ 0xFF	0x00	0x75	0x00	On:0x01 Off: 0x02	Checksum	Backlight Status Response



Query Command	Byte 1	Byte 2 (Address)	Byte 3	Byte 4	Byte 5	Byte 6	Byte 7	Comments
Response								
Query MIRROR Response	0xFF	0x00 ~ 0xFF	0x00	0x77	0x00	0x01:Normal 0x02:Mirror 0x03:Flip 0x04:Mirror+Flip	Checksum	Mirror & Flip Status Response
Query FREEZE Response	0xFF	0x00 ~ 0xFF	0x00	0x79	0x00	On:0x01 Off: 0x02	Checksum	Freeze Status Response
Checksum = Mod((Byte 2 + Byte 3 + Byte 4 + Byte 5 + Byte 6), 0x100);								